



Calc-An-Acre II

Speed, Area, Distance, RPM Monitor

System Manual

CALC-AN-ACRE[®] II

Speed, Area, Distance and RPM Monitor

REFERENCE MANUAL

Calc-An-Acre II is an electronic monitor for speed, area worked, distance and shaft RPM. Calc-An-Acre II has been designed for easy installation and operation. However, since each installation will vary depending on your equipment, please take time to familiarize yourself with this manual and the actual components before beginning. Following the procedures described in this manual will ensure proper performance and help avoid problems or questions once you are in the field.

This manual is written for the Calc-An-Acre II, which may be used for English, Metric or Turf measurement. Please read the manual carefully and follow the instructions as they apply to your usage.

If you do encounter a problem that cannot be corrected by reviewing this manual, consult your dealer or distributor, or contact a Micro-Trak technician for assistance.

Toll Free in U.S. or Canada: (800) 328-9613 or (507) 257-3600

E-mail: trakmail@micro-trak.com

Web: www.micro-trak.com



1305 Stadium Rd.

Mankato, MN 56001-5355

Copyright © 2021 Micro-Trak Systems, Inc.

All rights reserved.

Micro-Trak Systems, Inc. Limited Warranty Statement

Micro-Trak Systems, Inc. (herein "Seller") warrants to the original purchaser (herein "Buyer") that, if any product or part of the product (herein "Parts") proves to be defective in material or workmanship, upon inspection and examination by Seller, within three (3) years from the original date-of-purchase, and is returned to Seller with dated proof-of-purchase, transportation prepaid, within sixty (60) days after such defect is discovered, Seller will, at their option and sole discretion, either repair or replace said part, except that the warranty for expendable Parts, including but not limited to, light bulbs, batteries, hose and tubing, nuts, bolts, screws and other fasteners shall be thirty (30) days from the original date-of-purchase; and except that the warranty for Parts manufactured by someone other than the Seller, including but not limited to, shut-off valves, control (servo) valves, flowmeters, pressure sensors and regulators, pumps, motors, compressors, tanks and tank accessories, DGPS receivers and related repeater and base stations shall be one (1) year from the original date-of-purchase; and except that the warranty for Parts manufactured by someone other than the Seller, including but not limited to, memory cards and drives, mapping software, terminals, PC's, laptops, tablets and other computer devices shall be thirty (30) days from the original date-of-purchase. Any damage or failure to said part resulting from abuse, misuse, neglect, accidental or improper installation or maintenance, unauthorized modification, use with other parts and/or products, or attributable to acts of God, as determined solely by the Seller, will invalidate the warranty. Said part will not be considered defective if it substantially fulfills the performance specification. Buyer shall be responsible for all maintenance services, if any, all in strict accordance with the procedures outlined in the manual. The warranty does not include labor, installation, replacement parts or repairs, delivery of replacement parts or repairs or time and travel. Said warranty is non-transferable.

THE FOREGOING WARRANTY IS EXCLUSIVE AND IN LIEU OF ALL OTHER WARRANTIES OF MERCHANTABILITY, FITNESS FOR PURPOSE AND OF ANY OTHER TYPE, WHETHER EXPRESS OR IMPLIED. THE SELLER'S LIABILITY, WHETHER IN CONTRACT, IN TORT, UNDER ANY WARRANTY, IN NEGLIGENCE OR OTHERWISE, SHALL NOT EXCEED THE RETURN OF THE AMOUNT OF THE PURCHASE PRICE PAID BY THE BUYER, AND UNDER NO CIRCUMSTANCES SHALL THE SELLER BE LIABLE FOR SPECIAL, INDIRECT, CONSEQUENTIAL, INCIDENTAL OR PUNITIVE DAMAGES. SELLER NEITHER ASSUMES NOR AUTHORIZES ANYONE TO ASSUME FOR IT ANY OTHER OBLIGATION OR LIABILITY IN CONNECTION WITH SAID PART. NO ACTION, REGARDLESS OF FORM, ARISING OUT OF THE TRANSACTIONS UNDER THIS AGREEMENT MAY BE BROUGHT MORE THAN ONE (1) YEAR AFTER THE CAUSE OF ACTION HAS OCCURRED.

Buyer accepts these warranty terms and limitations unless the part is returned to Seller, via proper distribution channels and approved return authorization, with dated proof-of-purchase, transportation prepaid, within sixty (60) days from the date-of-purchase for refund of the purchase price.

Source Doc: MTS Warranty Statement 080120

MAIL and UPS:

**Micro-Trak® Systems, Inc.
ATTN: Service Department
1305 Stadium Rd.
Mankato, MN 56001-5355**

At Micro-Trak® Systems, we believe a product that delivers quality and performance at a reasonable cost is what is needed to help today's operator and the operator of the future compete in the world market.

It is our goal to provide operators with a line of electronic equipment that will help build and maintain an efficient and profitable operation that can be passed on to future generations.

We thank you for your purchase and hope that we can be of service to you in the future.

Micro-Trak® Systems, Inc.

Table of Contents

Micro-Trak Warranty.....	3
Table of Contents	4
Component Parts and Assembly Hardware.....	5
Wiring Diagram.....	6
System Overview	7
Installation.....	7
Console Mounting	7
Electrical Installation	8
Speed Sensor Options	9
Astro Speed Sensor Installation	9
Magnetic Speed Sensor Installation.....	10
Optional Remote Run/Hold Kit Installation.....	11
Optional Shaft RPM.....	12
Calc-An-Acre II Console Functions.....	13
Calibration	14
English/Metric Selection	14
Entering Calibration Values	15
Fine Tuning Speed/Distance Cal.....	17
Operation.....	18
General	19
Width Reduction: On-The-Go	19
Rotary Switch Positions.....	19
Resetting System Counters.....	20
Troubleshooting.....	20
Messages/Warnings.....	20
General	21
Checking Individual Components.....	22
Checking Console Inputs.....	23
Appendices	24
Appendix A - Optional Speed Sensor Mounting Installation.....	25
Optional Speed Sensor Mounting Installation on Drive Shaft	26
Appendix B - Radar "Y" Adapter Cables	27
Appendix C - Conversion Chart.....	28
Appendix D - Replacement Parts	29

Component Parts and Assembly Hardware

Before beginning installation, check the carton contents for the following items:



Calc-An-Acre II Console
P/N 17185



Owner's Manual
P/N 17192

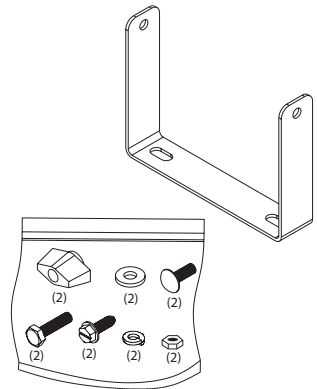

Console Mount Kit
P/N 13181

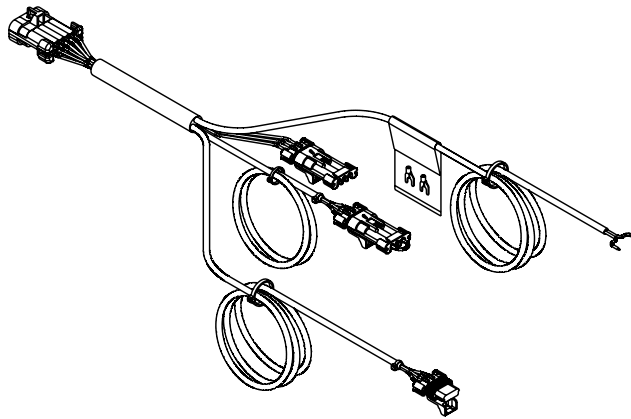

Power/Speed/Run-Hold/RPM Harness
P/N 17176

Note: Calc-An-Acre II "Customized" kit P/N 01001 does not include the P/N 01530 Speed Sensor kit shown below.

Speed Sensor Kit P/N 01530

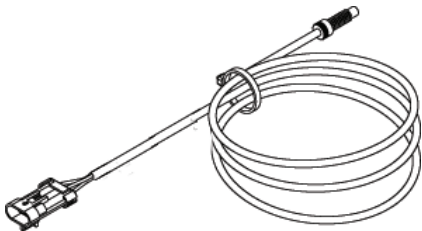

5' Hall-effect Speed/Flow
Sensor Cable P/N 13096

14" Nylon cable ties (10)
Kit P/N 12910

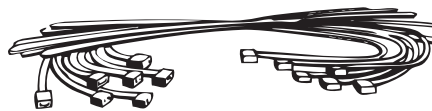

Hardware Bag
P/N 13251

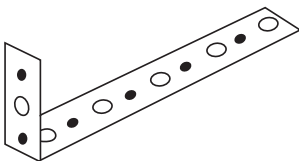

Speed sensor mounting bracket
P/N 10013

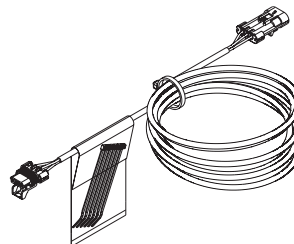

10' 3-Pin Extension Cable
M/P 150 P/N 13206

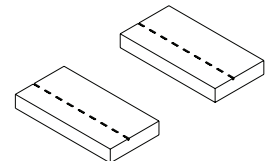

Magnets (6) P/N 12069
(2 add'l in hardware bag)

Calc-An-Acre II Wiring Diagram

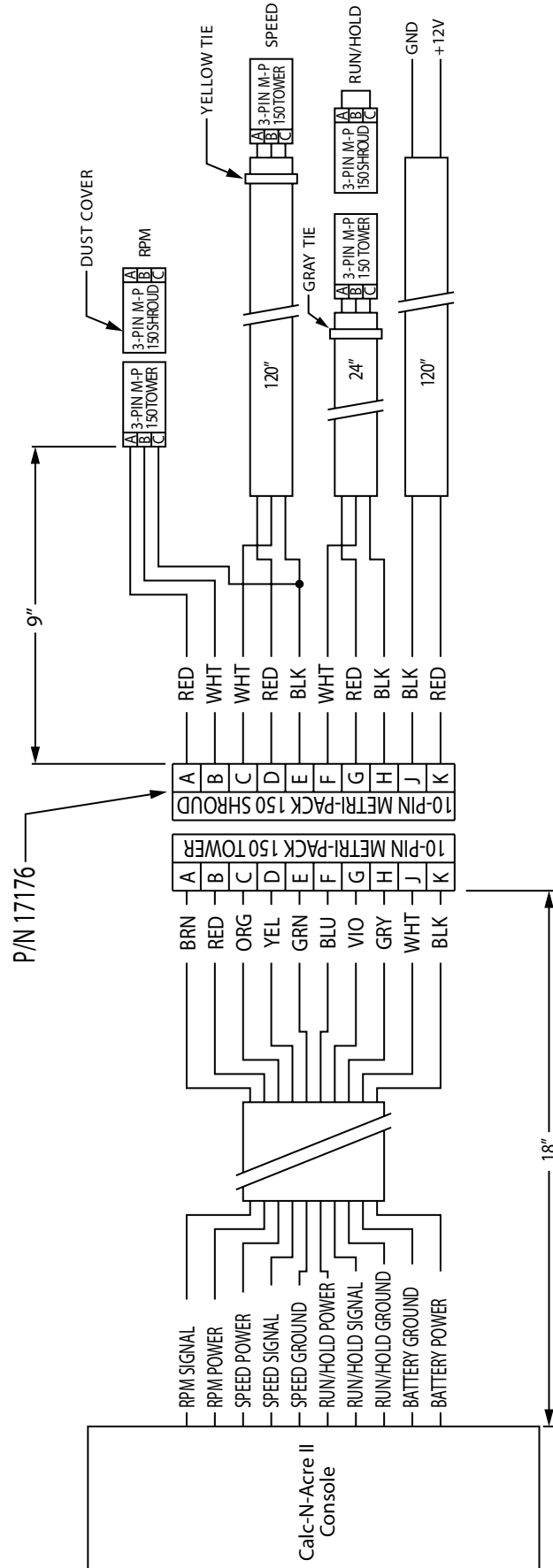

Calc-An-Acre II System Overview

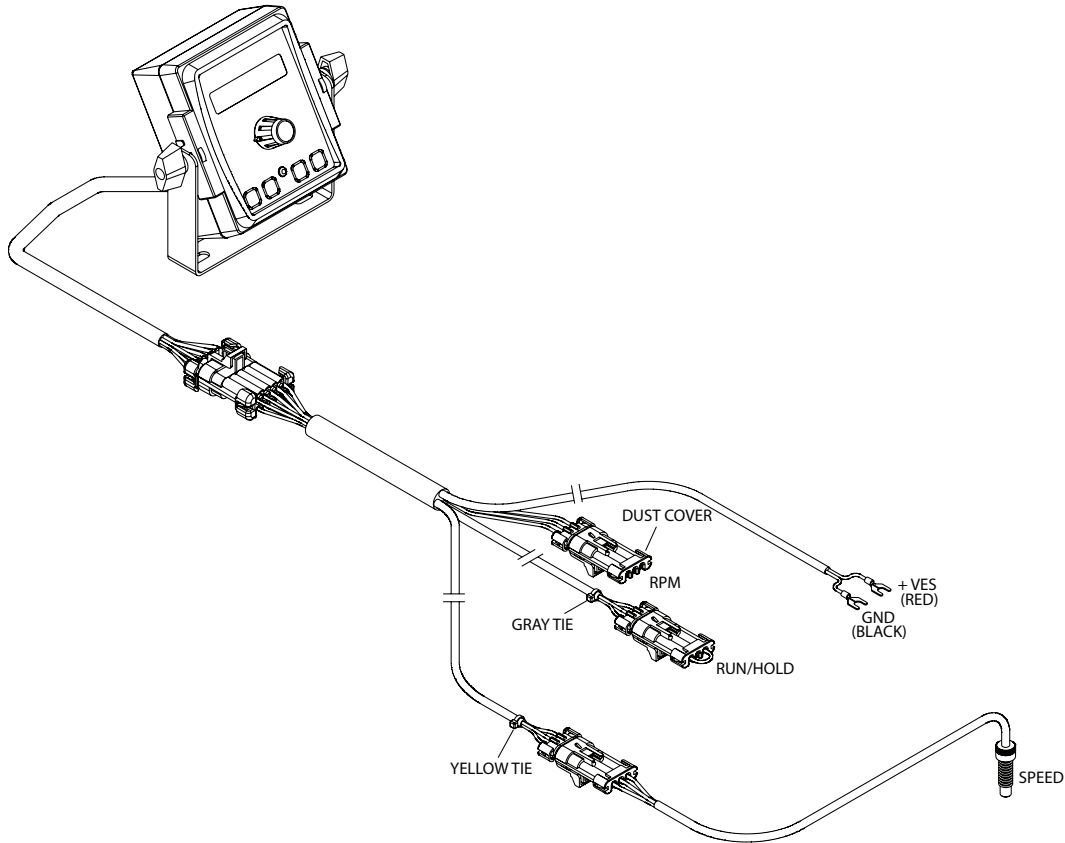

Installation Console Mounting

Select a practical mounting location, convenient to reach and easily visible to the operator. **DO NOT INSTALL IN A POSITION THAT OBSTRUCTS THE VIEW OF THE ROAD OR WORK AREA.** Whenever possible, avoid locations that expose the console to direct sunlight, high temperature, strong chemicals or rain. Console may be mounted to horizontal or vertical surface - adjust tilt for best visibility.

Place the mounting bracket in selected location, mark holes, drill 1/4" (7mm) holes and mount bracket with bolts, lockwashers and nuts provided.

(Use self-tapping screws if not practical to use bolts.)

Console Bracket

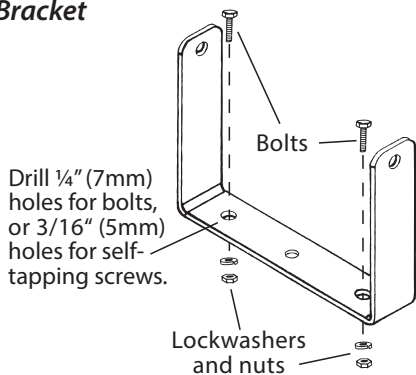

Put rubber washers on carriage bolts and put the bolts through the bracket holes from the inside out. Loosely attach the mount knobs onto the bolts. Place console over carriage bolt heads and tighten knobs to secure the console.

Console Mounting Detail

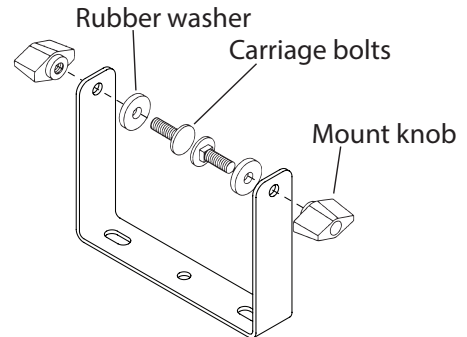

Installation (cont.)

Electrical Installation

This section explains how to hook-up your Calc-An-Acre II to a 12VDC power connection. The Calc-An-Acre II must be connected to a 12VDC negative ground electrical system.

ROUTING HARNESS AND CABLING

Avoid areas where the cable may be subjected to abrasion or excessive heat.

WIRING HARNESS ORIENTATION

Wiring with multiple branches must be installed so that the individual wires point downward, as shown. This will protect the internal connections from exposure to liquid chemicals.

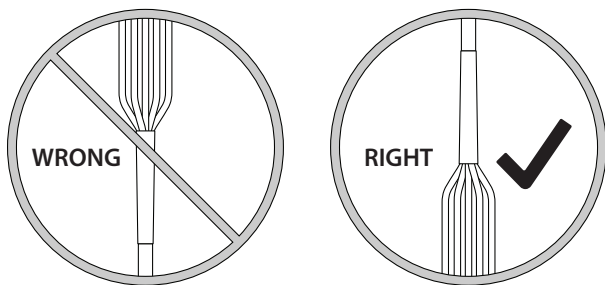

POWER CONNECTION

Locate the power cable lead on the Calc-An-Acre II harness and route to a switched +12VDC source. Attach the BLACK wire to ground. Connect the RED wire to positive terminal. If using an unprotected circuit as +12VDC source, add a 2A inline fuse (not included in kit.)

Alternately, the Calc-An-Acre II can be powered directly from the battery along with a power switch (not included in kit.)

Note: Ensure clean metal-to-metal contact from wiring to terminals.

Calc-An-Acre II is equipped with a non-volatile memory which does not require a constant supply of power to retain daily totals or calibration values.

Example of power connection to switched ignition source

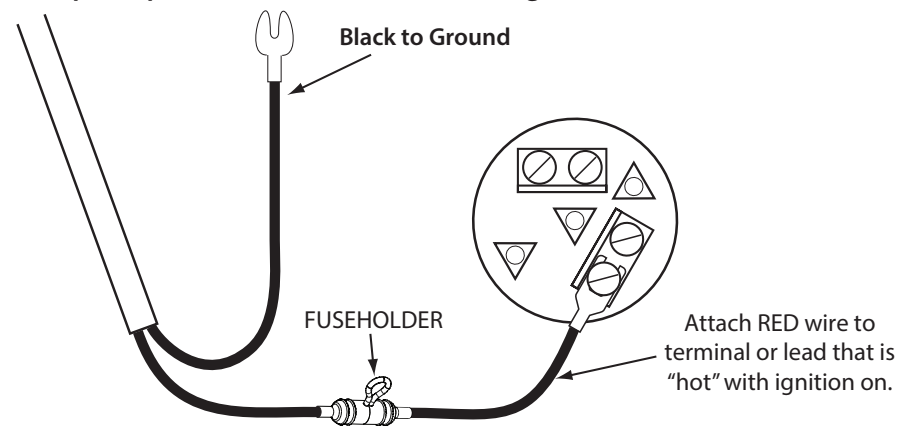

2-amp in-line fuse required (Not Provided) for unprotected circuits

Installation (cont.)

Speed Sensor Options

The Calc-An-Acre II must be connected to a speed sensor to utilize its calculating function.

Several possible options are listed below:

ASTRO SERIES OR OTHER GPS SPEED SENSOR INTERFACES

The Calc-An-Acre II is designed to easily connect to the Micro-Trak Astro series speed sensor. It also may be used with most GPS speed sensors that output a pulsed signal, such as the Squibb-Taylor® SkyTrak or Dickey-John® GPS speed sensors. An adapter cable may be required.

MAGNETIC WHEEL SENSOR

This system uses magnets attached to a wheel hub or drive shaft and a hall-effect sensor. The movement of the magnets near the sensor creates an electrical pulse which the console uses as a speed input. The system must be carefully calibrated to ensure accurate readings.

VANSCO™ RADAR SPEED SENSOR (AVAILABLE FROM MICRO-TRAK DEALERS & DISTRIBUTORS)

The Vansco radar speed sensor uses a microwave (radar) signal to deliver a reliable, accurate speed signal for electronic equipment. It features state-of-the-art electronic design/manufacturing, rugged aluminum housing and complete testing and certification.

RADAR INTERFACE

The Calc-An-Acre II may also be interfaced with most popular radar ground speed sensors. An adapter cable is required for proper interface.

SEE Appendix B FOR LIST OF ADAPTER CABLES FOR RADAR.

PROXIMITY SENSOR - P/N 01554

The proximity sensor is useful in situations where it is impractical or inadvisable to use other options. The P/N 01554 Proximity Sensor responds to the close presence of ferrous metals and sends a signal to the console via Speed connection. Typically it is mounted near the teeth of sprocket using a recommended air gap of 1/16" (tip: use a U.S. dime as a gauge).

To calibrate the system to use this sensor for speed use pg. 18 Fine Tuning Speed/Distance.

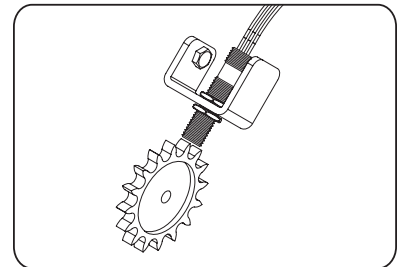

Astro Speed Sensor Installation

RECEIVER: The GPS receiver may be mounted either externally (roof of the cab or other place with a clear view of the sky) or inside the vehicle cab. However, if mounted inside the cab there may be some loss of accuracy due to blockage of satellite signals. For most reliable operation, mount the GPS receiver in a location where it has an unobstructed view of the sky. Mount the receiver using the integral magnet or the included self-adhesive fastener tape. If using the fastener tape - clean the mounting location, remove the plastic backing, and press firmly to the surface.

WIRING: Route the 10 foot cable from the receiver into the cab (if receiver is externally mounted). Avoid sharp edges or heat sources. The rectangular module is roughly the same size as the connector and will fit through the same opening.

MODULE: The small potted module includes a power LED and a GPS status LED. The module can be mounted in a visible location using the included self-adhesive fastener tape, or placed out of sight.

- **Power LED** (closest to connector) : On when 12VDC is connected
- **GPS Status LED** (closest to receiver): Flashes when the GPS receiver is active and scanning for a satellite. When a signal is found, it will remain on. If the GPS system fails, the light will turn off.

CONSOLE CONNECTION: Connect the short cable from the Astro to the 3-pin connector labeled SPEED on your console.



Installation (cont)

Magnetic Speed Sensor Installation

Magnet Locations

1. Non-driven wheel on tractor, vehicle or implement - less susceptible to errors resulting from wheel slip.
2. Tractor, vehicle or planter drive shaft. This type of mounting is recommended for trucks, four-wheel drive tractors or other equipment that has limited access to a non-driven wheel.

Number of Magnets

The number of magnets that must be used depends on the size of your tire and where you mount the sensor. On tractor or implement wheels the general rule of thumb is one magnet for each wheel bolt (minimum of two, and always an even number). For drive shafts or small wheels (ATV's), two magnets are usually adequate.

Some installations may require that more than two magnets be installed. To determine the number of magnets required, measure the distance traveled of one revolution of the sensor equipped wheel in inches (meters). Divide that measurement by 20 for English and Turf units, or by .5 for Metric units, and then round up to the nearest even number (always use an even number of magnets). That number will be the minimum number of magnets required for the installation.

Example in English/Turf units: If your revolution measurement is 97 inches, dividing that number by 20 gives you a value of 4.85. Rounding 4.85 up to the nearest even number is 6. For this example, the minimum number of magnets required is 6.

Example in Metric units: If your revolution measurement is 2.5 meters, dividing that number by .5 gives you a value of 5. Rounding 5 up to the nearest even number is 6. For this example, the minimum number of magnets required is 6.

The magnets provided by Micro-Trak® are marked with a punched dashed line on the SOUTH pole side of the magnet.

Always use an even number of magnets, and always alternate the polarities of the magnets as you go around the wheel hub or drive shaft.

To install, mount the first magnet with the SOUTH pole side (dashed line) facing toward the hub or shaft. Mount the second magnet with the NORTH pole side facing toward the hub or shaft.

For proper operation, the magnets must be evenly spaced around the wheel or drive shaft. The magnets must be at least 1" apart.

Attaching Magnets

The magnets are attached to a wheel hub or drive shaft and the speed sensor is mounted directly over the magnet. When the wheel or drive shaft begins turning, a speed impulse is sent to the Calc-An-Acre II console every time a magnet passes by the tip of the speed sensor. For the speed sensor to operate properly, the spacing between the magnets and the tip of the sensor must always remain constant. Before permanently mounting any parts, be sure that the location you have selected will meet the following requirements.

NOTE: Magnets must alternate in polarity.

Locate the Following Parts

- Speed Sensor Cable (Green Body)
- Mounting "L" Bracket
- Magnets
- Cable Ties

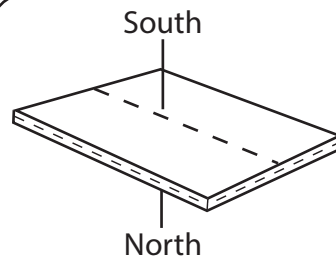

Magnet Polarity

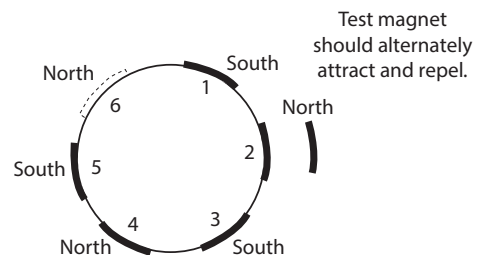

Magnet Layout

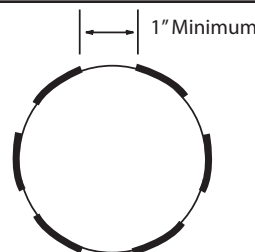

Magnet Spacing

NOTE: Magnets may be attached mechanically or adhered with epoxy or other high quality adhesive. When using adhesive, thoroughly clean the area of dirt and oil.

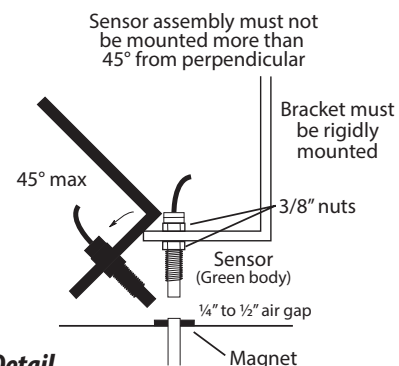

Mounting Detail

Installation (cont)

Magnetic Speed Sensor Installation

Connecting the Speed Sensor Cable

The speed sensor cable has a GREEN sensor body and joins the 3-pin connector which is marked with a YELLOW cable tie. The optional Run/Hold and RPM sensors are identical, and use the same type of connector as the speed sensor. The Run/Hold sensor body is BLACK and connects the main harness cable with a GRAY tie near the 3-pin connector. The RPM sensor body is BLACK and connects to the main harness 3-pin connector with no color tie. See Calc-An-Acre II Wiring Diagram on page 6.

SENSOR IDENTIFICATION CHART

SENSOR	SENSOR BODY COLOR	MAIN HARNESS TIE COLOR
Speed	Green	Yellow
RPM	Black	None
Run/Hold	Black	Gray

Remote Run/Hold Installation (Requires Optional Kit # 01535)

The run/hold sensor cable has a BLACK body and mates with the main harness cable having a GRAY cable tie near the 3-pin M/P connector. Make certain that you install the correct sensor cable and connect it to the correct connector on the main harness.

IMPORTANT

If not using Run/Hold cable for remote use, make certain a dust cover with jumper is installed.

- Attach a magnet to a lever or some part of the equipment that moves when the implement is raised and lowered. The Hall-effect Run/Hold sensor is sensitive **ONLY** to the south pole of the magnet. Install the magnet with the dashed line facing the sensor. When the magnet is away from the sensor, the console will be in HOLD and the area and distance counting functions will be disabled.

NOTE: The run/hold kit includes a 5' sensor cable and 10' extension. You may require additional extension cables which are available in 5 ft. (1.5 m), 10 ft. (3 m), 15 ft. (4.5 m), 20 ft. (6 m) and 25 ft. (7.6 m) lengths.

- You may also use a toggle or other type switch. Simply cut the black jumper wire in the dust cover and splice on an appropriate length of wire to reach your switch. **DO NOT** connect to a switch with power.

When switch is closed, console is in RUN. When the switch is open, the console is in HOLD.

P/N 01535 Remote Run/Hold Kit

Includes items:

- P/N 13226 5' Run/Hold Sensor Cable
- P/N 13206 M/P 150 10' Extension Cable
- P/N 13251 Hardware Bag (incl. magnets)
- P/N 10045 14" Nylon cable ties (5)
- P/N 10013 Speed Sensor Mounting Bracket

Lift Wheel Mounting

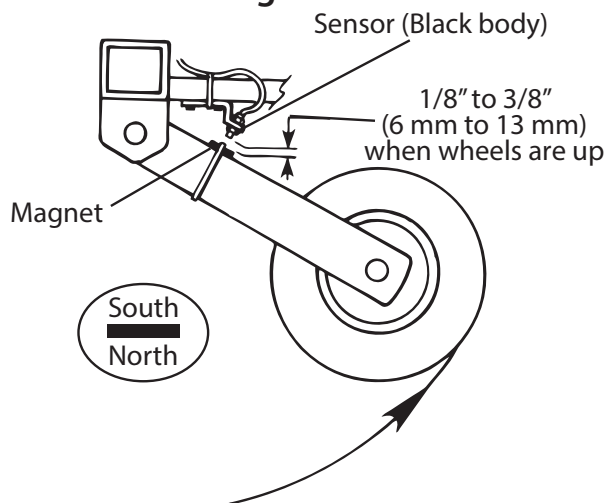

Hydraulic Cylinder Mounting

Remote Run sensor on hydraulic cylinder. Magnet and sensor are in line when equipment is lowered and operating.

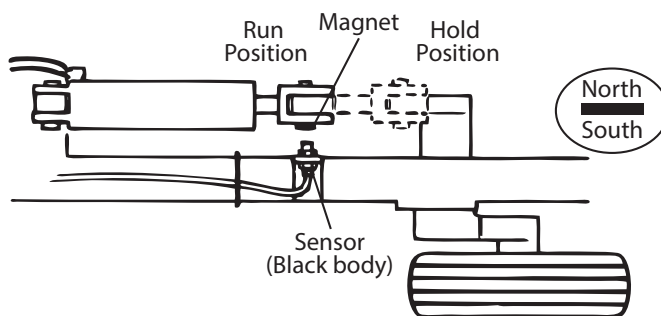

Installation (cont)

Shaft RPM (Requires Kit # 01539)

Locate the following parts (in optional kit #01539):

- P/N 13226 Shaft sensor cable (black body)
- P/N 13251 Magnets (and hardware)
- P/N 10045 2 Cable ties
- P/N 10013 Bracket

Mount magnet with SOUTH pole (dashed line) facing tip of sensor. Some installations may require more than one magnet per shaft. The magnets provided by Micro-Trak are marked with a dashed line on the SOUTH pole side of the magnet.

INSTALLATION: For proper operation, the magnets must be evenly spaced around the shaft. The magnets must be at least 1" apart.

NOTE: magnets may be attached with a cable tie or adhered with epoxy or other high quality adhesive. When using adhesive, thoroughly clean the area of dirt and oil. Use of cable ties or other mechanical attachment is recommended, however.

The shaft sensor is mounted directly over the magnet. For the shaft sensor to operate properly, the spacing between the magnets and the tip of the sensor must always remain constant. Before permanently mounting any parts, be sure that the location you have selected will meet the mounting requirements. Note that magnets can be closer than 1" apart only if another magnet with opposite polarity is mounted between each of the south-faced magnets. **NOTE: Observe magnet polarities.**

P/N 01539 RPM Sensor Kit

Includes items:

- P/N 13226 5' Run/Hold Sensor Cable
- P/N 13251 Hardware Bag (incl. magnets)
- P/N 10045 14" Nylon cable ties (5)
- P/N 10013 Speed Sensor Mounting Bracket

Magnet Polarity

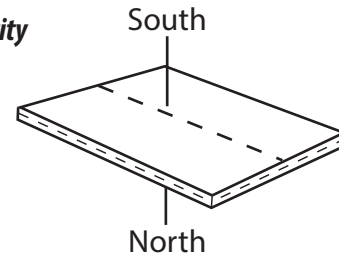

Magnet Layout

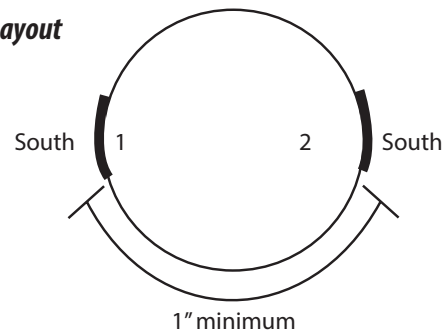

NOTE: Magnets can be placed closer than 1" apart if a magnet with opposite polarity is placed between them.

Mounting Detail

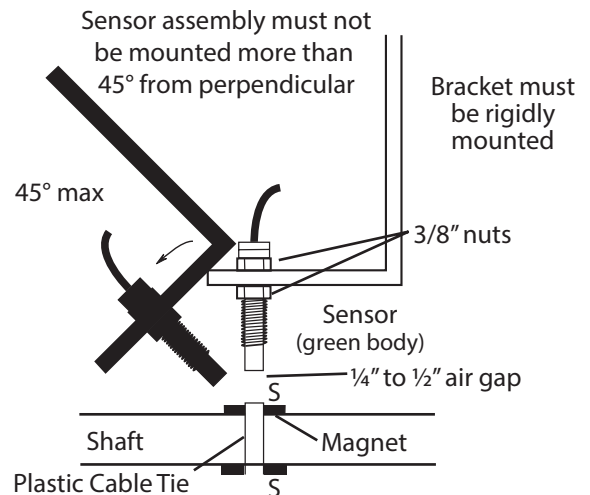

Calc-An-Acre II Console Functions

The Calc-An-Acre II features a large, easy-to-read liquid crystal display, easy-to-use rotary dial and lighted display.

AREA (1) (2) (3): Three independent counters keep a running count of the total acres (hectares) (thousands of square feet) worked. May be reset.

SPEED: Displays ground speed in miles per hour (kilometers per hour).

AREA/HOUR: Displays current work rate in acres per hour or hectares per hour or thousands of square feet per hour.

TOTAL HOURS: Shows hours of operation (can be reset).

RPM: Displays shaft RPM (requires Shaft Sensor Kit P/N 01539)

DISTANCE: Displays distance traveled in feet (meters). May be reset.

WIDTH +/-: Displays effective working width. Width can be changed on the go, in 25% increments.

SUB HOURS: Shows sub hours of operation (can be reset).



Calibration Positions

SHAFT CAL: Used in calibration mode to enter shaft pulses per revolution (for RPM readout)

SPEED CAL: Used in calibration mode to enter the speed calibration number in inches (cm) per pulse.

Calibration Positions

WIDTH CAL: Used in calibration mode to enter the working width of your sprayer booms or other equipment.

UNITS: Used in calibration mode to select between English, Metric and Turf.

Key Functions:



RUN/HOLD: Key which changes between Run and Hold modes of operation.



CAL: This key is used to enter & exit the calibration mode.



PROGRAM KEYS: Used to increment and decrement the different calibration values.



- RESET when not in CAL, clears the selected counter when held for two seconds while in HOLD.
- When in CAL, or Width +/-, the "+" key increases and the "-" decreases the value displayed.

Care and Maintenance of your Calc-An-Acre II

Store the console in a cool dry location if it will not be used for an extended period of time, such as during the off-season. As with any electronic equipment, use care in cleaning so that water or other liquids do not enter the case.

Calibration

English or Metric?

The Calc-An-Acre II is capable of displaying information in American English or standard Metric or Turf measurement units. The Calc-An-Acre II is shipped from the factory programmed for English. Note that the following procedures will also load factory default calibration values. To simply change units without loading defaults, *see the Calibration section on next page.*

METRIC

- To activate the Metric mode, turn power OFF and place the rotary switch at "RPM." Hold down both the "CAL" and "-" keys and turn power ON. The console will display LOAd. Once LOAd is displayed, release the two keys. To "lock-in" Metric mode you must enter and exit calibration. You must be in HOLD to enter Cal. Press and hold the CAL key until "CAL" icon appears on the display. The console is now in calibration and Metric mode is selected. Exit CAL by pressing and holding the "CAL" key until CAL disappears from the display (approximately 1 second).

NOTE: you must exit CAL to lock in Metric units.

It is also possible to instantly save factory defaults during the above procedure by pressing and holding down the "CAL" and "-" keys for 3 seconds until the screen reads "StorE".

ENGLISH

- To activate the English mode, turn power OFF and place the rotary switch in the AREA position. Hold down both the "CAL" and "-" keys and turn power ON. The console will display LOAd. Once LOAd is displayed, release the two keys. To "lock-in" English mode you must enter and exit calibration. You must be in HOLD to enter Cal. Press and hold the CAL key until "CAL" lights on the display. The console is now in calibration and English mode is selected. Exit CAL by pressing and holding the "CAL" key until CAL disappears from the display (approximately 1 second).

NOTE: you must exit CAL to lock in English units.

It is also possible to instantly save factory defaults during the above procedure by pressing and holding down the "CAL" and "-" keys for 3 seconds until the screen reads "StorE".

NOTE: In metric, the width will have a decimal point, in English there is no decimal point. Also, changing from English to Metric mode may change or alter any previously entered calibration values. After switching measurement modes, confirm that all calibration values are correct.

IN ALL CALIBRATION OPERATIONS:

- Put system in "HOLD".
- Press and hold the "CAL" key for 1 second to select the calibration mode. The console display will display the "CAL" icon, and the currently selected calibration value.
- Turn the rotary dial to the desired "CAL" position. Then use the "+" or "-" key to adjust the displayed value up or down as needed. Adjust ALL necessary values. Hold the "CAL" key again for 1 second to exit calibration. "CAL" will disappear from the display. NOTE: You must exit CAL to save changes.

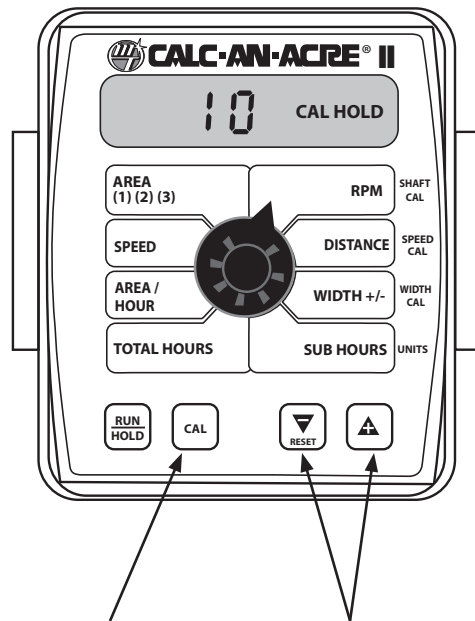
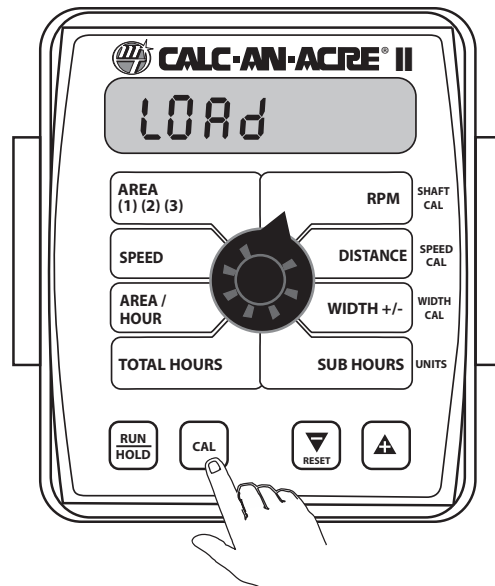

Press to enter or exit calibration mode.

Press to increase or decrease values.

Calibration (cont)

Entering Calibration Values

UNITS: Choose the system of units desired. Use the "+" and "-" buttons to choose between EnG (American English Units), mEt (Metric) and turF (Turf units). Turf units are the same as English units except Area is in thousands of square feet.

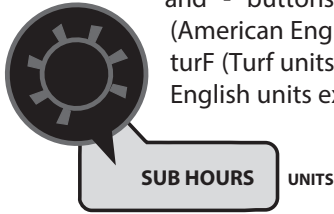

WIDTH: Enter the effective working width, in inches (meters). Your "working" width per boom section will be the number of nozzles on the boom section times the nozzle spacing in inches (mm). For example, if you have 7 nozzles spaced at 20 inches, the working width of the boom section is 140 inches.



SHAFT CAL: This position is used to calibrate a shaft RPM sensor. A P/N 01539 Shaft RPM Sensor Kit is required. When this position is selected, the display will show the SHAFT CAL value (pulses per revolution). A SHAFT CAL value from 1-255 may be entered using the "+" and "-" buttons, corresponding to the number of magnets mounted on the Shaft. *See page 10.*

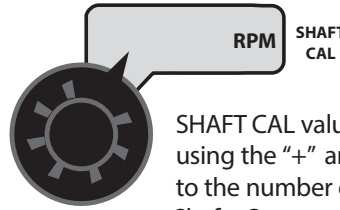

SPEED CAL: This position is used to calibrate the speed sensor for accurate speed and distance measurement. When this position is selected, the display will show the SPEED CAL value. *See next page for details.*

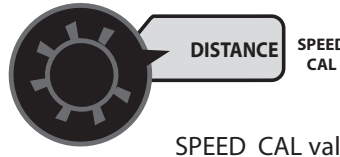

Speed Cal for Radar or GPS Speed Sensors

See the following table for SPEED CAL numbers to enter for various radar models or GPS speed sensors.

RADAR OR GPS SPEED SENSOR CALIBRATION

Radars	English Cal # in.	Metric Cal # in.	Hz/MPH
Vansco	.150	.38	58.90
Raven	.148	.38	59.80
Magnavox	.154	.39	57.40
Dickey-john (NOTE: Dickey-john radars may be factory calibrated for any of these four settings).	.149	.38	58.94
	.199	.51	44.21
	.319	.81	27.64
	.518	1.32	17.034
GPS Speed			
Astro II & 5	.189	.48	46.56
SkyTrak (Std)	.150	.38	58.94
SkyTrak (MT)	.910	2.31	9.82
Dickey-john	.210	.53	42.00
John Deere (In-cab spd signal)	.197	.50	44.70

Factory-Loaded Calibration Values

Calibration Factor	Measurements Effected	Default Values	
		English	Metric
WIDTH	Area, Area/Hour	720 inches	18.000 meters
SPEED CAL	Distance, Area, Area/Hour	.189 inch/edge	.48 cm/edge
RPM	RPM Display	1 pulse/revolution	1 pulse/revolution
UNITS	Distance, Area, Area/Hour ¹⁷	English	Metric

Calibration (cont)

Entering Calibration Values (cont)

Determining the SPEED CAL (Skip this section if using radar or GPS speed sensor)

For the console to calculate the correct speed and measure distance accurately, the circumference of the sensor-equipped wheel must be entered. Determine the circumference of the sensor-mounted wheel to the nearest tenth of an inch (tenth of a centimeter) with the following method:

METHOD

Mark the tire with a piece of chalk and measure the distance traveled on the ground for one complete revolution. *See Illustration.* For improved accuracy, it is recommended that you perform this function in field conditions, measure several revolutions, and take the average.

Divide the measured revolution by the number of magnets installed to get your starting SPEED CAL calibration value. Once calibration of the system is complete, this number should be fine-tuned for optimum accuracy.

For fine-tuning the SPEED CAL value, see following page.



To determine SPEED CAL, measure the distance of one complete wheel revolution and divide by the number of magnets installed.

Drive Shaft Speed Sensor Calibration

NOTE: If you have mounted the magnetic speed sensor on a wheel, skip this step and go on to Fine Tuning Speed/Distance Calibration Values.

Because of the difference in wheel-to-drive shaft ratios, it is difficult to determine a calibration value for installation on a drive shaft by measuring a wheel. You must start with an estimated calibration value and then fine-tune the calibration.

Any number between 10 and 15 (255 mm to 380 mm) is a good starting value.

NOTE: For fine-tuning the SPEED CAL value, see following page.

Calibration (cont)

Fine Tuning Speed/Distance Calibration Value

PREPARATION

In order to achieve accurate measurements, each step in this fine tuning procedure should be performed as precisely as possible.

1. Once the system is fully installed and calibrated, select a straight tract of ground that is similar to your actual field conditions and as level as possible.
2. Measure a distance of 1000 feet (500 meters). Clearly mark the beginning and end points with flags or something highly visible to the operator.

NOTE: Using a course with a different ground surface, such as a hard surface road, will result in different readings than exact field conditions.

PROCEDURE

1. With the console turned ON, use the Run/Hold button to select HOLD mode. The HOLD icon will be displayed. Turn the rotary dial to the "DISTANCE" position. Be sure the display shows 0. If not, reset the distance counter by pressing and holding "RESET" until the display return to 0 (approximately one second). The word CLEAR will be displayed when reset is pressed.
2. You are now ready to drive the measured course. Pick a location on the vehicle to use as a marker for starting and stopping the distance counting function (door handle, mirror, step, etc.). You should begin driving the course well ahead of the starting flag and drive past the ending flag, using the Run/Hold button to start and stop the counting function. It is not recommended to start from a dead stop at the starting flag and stop at the ending flag.
3. Use the Run/Hold button to select RUN mode, when the marker on the vehicle passes the starting flag to activate the distance counting function. The console display numbers will increase, adding to the distance total as you drive. Drive the pre-measured course and use the Run/Hold button to select HOLD mode, when the marker on the vehicle passes the ending flag, to stop the distance counting function. The console display should read "HOLD". Stop the vehicle in a level and safe area and continue with this procedure.
4. With the rotary dial still at DISTANCE (SPEED CAL), press and hold the "CAL" key for one second. Once the console is in "CAL", CAL and the speed calibration number will be displayed. Momentarily press CAL and the word CAL will begin to flash and the distance traveled will be displayed. *See Illustration.*

5. When the display shows distance ("CAL" is flashing), verify whether the number displayed is the exact distance you drove (within + or - 1 - 2 %). If not, press the "+" or "-" key to adjust the figure to match the distance you actually drove. If the display reads too high, use the "-" key to lower the displayed value. If the display reads too low, use the "+" key to raise the displayed value.
6. When the number shown on the display matches (as closely as possible) the actual distance driven, you have arrived at the correct calibration value. If you cannot adjust the displayed distance to exactly match the actual distance driven, adjust the figure as close as possible to the actual distance. You may check the calibration number by momentarily pressing CAL. The word CAL and the SPEED CAL number will appear. Exit "CAL" by pressing "CAL" for one second.

The speed sensor is now calibrated. To verify proper calibration repeat the procedure a second time. Write down the new speed calibration number and keep it in a safe place. If the calibration values are ever accidentally changed, you can simply re-enter this number.

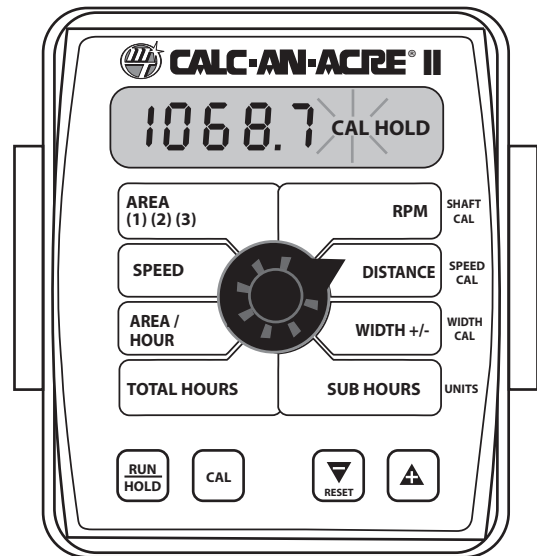

Operation

General

Make sure your system is properly calibrated before beginning to monitor speed, area, distance or RPM. The Calc-An-Acre II features an easy-to-use rotary dial. Simply turn the dial to the desired function. The console gives a continuous display of the function selected until another one is chosen.

CONSOLE POWER/SYSTEM ON/OFF

The system can be turned ON and OFF by the ignition switch. When the console is turned on, it will display the number of hours of operation for 2 seconds, then it will display the software version along with the "v" icon for 2 seconds before it begins normal operation.

DISPLAY and ROTARY SWITCH

During normal operation, the console will display information selected by the rotary switch position. The functions that are active during normal operation are the GREEN boxes. Calibration positions are identified by the WHITE labeling on the right side of the rotary selector (Please refer to Calibration section for details).

RUN/HOLD BUTTON

The RUN/HOLD is the master button for turning all counters on and off. This function can be done either manually with the RUN/HOLD button, or automatically, using the optional RUN/HOLD sensor kit (P/N 01535).

"+" AND "-" BUTTONS

During normal operation, when the rotary dial is set to WIDTH +/-, each press of the "+" or "-" buttons will increase or decrease the working width by 25%. See detailed description below.

Width Reduction - On the Go (OTG)

The effective working width that was entered during calibration, may be reduced in 25 percent increments during operation to account for changes in actual working width in the field.

In a full-width condition, the display will read "1 2 3 4". To change the working width on-the-go, turn the rotary switch to "WIDTH +/-". The display will show the current effective width in inches (mm). Each press of the "-" key will reduce the effective working width by 25 percent. The display will also show the change. If the "-" key was pressed twice, the display will now show "1 2" and the displayed width will read half of the calibrated full width.

If the width has been reduced from the full width, it will accumulate area based on the new width. When "HOLD" is selected, either by using the Run/Hold key or by a remote run/hold switch, the width will automatically default back to the calibrated width. Width may be reduced while in "HOLD". The default to full width occurs only when changing the system status from "RUN" to "HOLD, not when changing the system status from "HOLD to "RUN".

Rotary Switch Positions

AREA

Displays the acres (hectares) (thousands of square feet) covered since the counter was last reset to zero. The area counters do not accumulate area when the console is in HOLD. To select an AREA counter, use the "+" button to select set 1, 2 or 3, indicated by the small numbers in the lower right on the display. Do NOT use the "-" button to select a counter because the button will clear it. (See *Resetting System Counters - page 19.*) Each area counter may be reset to zero independent of other area counters, or other system counters.

SPEED

Displays the ground speed in miles (kilometers) per hour.

AREA/HOUR

Displays acres per hour (hectare per hour) (thousands of square feet per hour) being covered.

TOTAL HOURS

Displays hours of operation. The hours may be reset independent of the system counters. The hours do NOT accumulate when system is in HOLD.

RPM

Displays Shaft RPM (requires P/N 01539 Shaft Sensor Kit). See page 12 for more information.

DISTANCE

Displays the feet (meters) driven since the counter was last reset to zero. This counter does not accumulate when the console is in HOLD. This counter may be reset to zero independent of other system counters.

WIDTH +/-

Displays working width in inches (meters). Pressing the "+" or "-" button increments or decrements the working width by 25%. The working width reverts back to the Width Cal value when the Calc-An-Acre II power is turned off and back on. See the Calibration section page 15 for more information.

SUB HOURS

Displays sub hours such as for a particular area. The sub hours may be reset independent of other system counters. The hours do NOT accumulate when system is in HOLD.

Operation

Resetting System Counters

The AREA, DISTANCE, TOTAL HOURS and SUB HOURS counters maintain a running count during operation regardless of the position of the rotary switch. When any of these counters reach their maximum capacity, or when you want to start a new count, the value may be reset to zero by performing the following routine. Counters may be reset independently of each other.

1. Put the system in HOLD.
2. Turn the rotary switch to the counter to be reset.
3. To reset distance, total hours and sub hours, turn the rotary switch to the desired function and simply press and hold the RESET button until the display reads zero. The display will show the word "CLEAR" during this process, and will show 0.0 when reset to zero is complete.
4. To reset the area counters; there are three independent AREA counters. The active counter is indicated by the small numbers in the lower right area of the display (1,2, or 3) when the rotary switch is in the AREA position. Select the counter you want to use by pressing the "+" button. The small number will increment each time the "+" button is pressed (from 1 to 3, then rolls back to 1). DO NOT attempt to select the counter number by using the "-" button, because that will clear the active counter if held for 2 seconds. If the "-" button is accidentally pressed, the console will display "CLEAR" to alert the user that the counter will be cleared. If the user continues to hold the "-" button for 2 seconds "CLEAR" will disappear and be replaced by 0.0, indicating that the selected counter has been cleared.

To select an AREA counter: Verify that the desired counter is selected, or use the "+" button to select.

Display indicates that counter #1 is selected

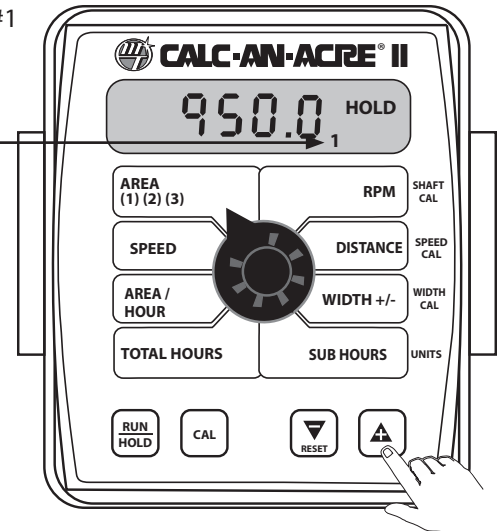

Display indicates that counter #2 is selected

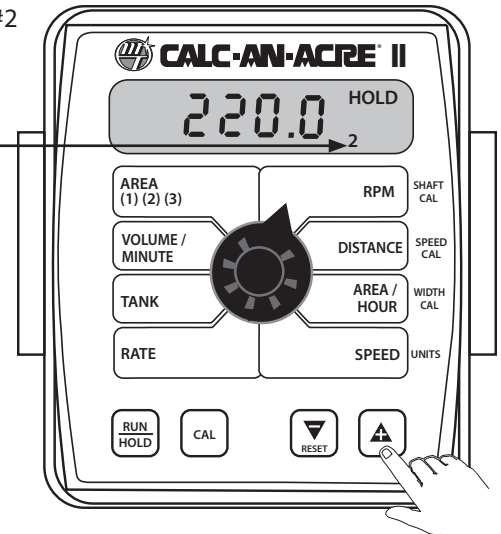

Display indicates that counter #3 is selected

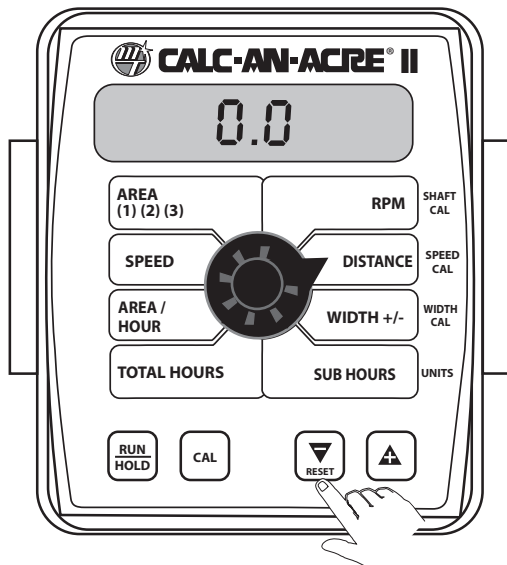
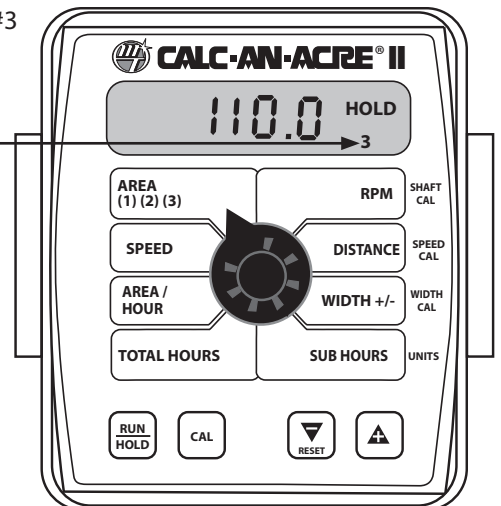

Troubleshooting

Messages/Warnings



This message appears when an error occurs while verifying calibration values during the power-up. Enter calibration and verify that the calibration values have not changed and exit calibration. Cycling power will not clear the bad CAL message. The message can only be cleared by entering and exiting calibration mode.



Low Power. Check all power and ground connections.



Has loaded Default Cal factors (appears when default calibration factors are loaded by holding CAL and "-" buttons while turning the console on).



Shows when Default Cal factors are saved in memory. This function takes place if CAL and "-" buttons are pressed and held down for more than 3 seconds when loading Default Cal factors.



On startup, the "V" is displayed next to the software version #. (Console hours displayed first.)



The message alerts the user that the currently selected counter will be cleared if held for 2 seconds. Also serves as a reminder to use "+" button to select AREA counters.

Troubleshooting (cont)

General

All Calc-An-Acre II consoles are tested prior to packaging, so unless there has been damage in shipment you can be confident that everything will be operational when you receive it.

However, if you do encounter a problem that appears to be related to equipment failure, **PLEASE DO NOT OPEN THE CONSOLE**. Your system is protected by a warranty, and Micro-Trak will gladly correct any defect.

Problems can be the result of mistakes in installation or operation. Before returning any parts for service, carefully check your installation and review the operating instructions. *For easy-to-follow guidelines, refer to the troubleshooting section which follows.*

CONSOLE APPEARS DEAD

Using your test light, check for 12 volts at the power source. Also check for damaged power cable or reversed terminals. (Console requires 12 volts for proper operation).

SPEED IS ALWAYS ZERO OR ERRATIC

Check for properly calibrated speed cal number.

Review speed sensor installation. Check for proper mounting, alignment and spacing of speed sensor in relationship to magnet assembly. Make sure magnet polarities are alternated. Also check cable for breaks or incomplete connection.

For more suggestions on solutions to speed problems, see Hall-effect sensors and console inputs on pages 23.

DISTANCE COUNT IS INACCURATE

Speed cal number was incorrectly calculated or entered.

Review calibration, re-adjust and test.

AREA COUNT IS INACCURATE

Working width or wheel circumference was measured incorrectly, or speed cal number was incorrectly calculated or entered. Go back through the original procedures, make changes, and test for acre (hectare) count again. Verify accuracy with formula:

Acres = Distance x Width in feet/43560

Hectares = Distance x Width in meters/10,000

Thousands of square feet = Distance x Width in feet/1000

CONSOLE IS ERRATIC IN OPERATION

If you have a two-way radio, it may be mounted too close to the console. Keep all Calc-An-Acre II cables away from the radio, its antenna and power cable.

Ignition wires may be causing the console to malfunction. Keep Calc-An-Acre II cables away from ignition wires, or install ignition suppressor.

Reroute all cable away from electric solenoids, air conditioning clutches and similar equipment.

DISPLAYED MEASUREMENTS DO NOT MAKE SENSE

The console may be in the incorrect measurement mode (English or metric). *See page 15 for instructions.*

DISPLAY READS "OFL"

DISTANCE, AREA, TOTAL HOURS and SUB HOURS counters read OFL when they have exceeded their maximum count. Reset to zero to resume counting.

Troubleshooting (cont)

Checking Individual Components

CONSOLE

The only way to field test a console is to connect it to a harness on a vehicle with a known working console or install it on a demonstration display stand.

HARNESS

The harness can be checked using an ohmmeter or continuity tester. The main wiring diagram shows the pin out of all connectors. *See page 6.*

ELECTRICAL INTERFERENCE

Erratic operation of the system may be the result of electrical interference from ignition wires or inductive loads (electrical clutch, fan, solenoid, etc.). Always try to route wires as far away from suspect areas as possible. If problems occur, you may need to relocate the console and/or wiring harness, or install a noise suppressor.

POWER

Check power source with a meter or a test light. If there is no power, trace cable toward battery looking for breaks. Also check any fuses or circuit breakers that supply power to the console.

ACCESSORY POWER

The speed, RPM and run/hold cables all have an accessory power wire. Check for 12 volts between B (usually white) and C (usually black) of these connectors. If power is not present, make sure the accessory power wire is not open or shorted to ground or to another wire. If this wire has a problem, the console may exhibit erratic behavior or not function at all.

RPM AND RUN/HOLD HALL-EFFECT SENSORS

Caution: Improper connection or voltage could damage the Hall-Effect sensor. The Hall-effect sensor works similar to a reed switch, but is solid-state (no moving parts) and requires power in order to function. The RPM and Run/Hold type of Hall-effect sensor “closes” when near the south pole of a magnet and is otherwise “open”.

Ground pin C (black) and connect clean 12 volts to pin B (white) of the Hall-effect sensor cable. Connect the positive lead (red) of an ohmmeter or continuity tester to pin A (red) and the negative lead (black) of the ohmmeter or continuity tester to pin C (black) of the Hall-effect sensor cable.

Holding the tip of the sensor up to the south pole (face with dotted line) of a magnet should result in a very low resistance (around 300 ohms). Taking the sensor away from the magnet should result in a very high resistance (infinite).

RUN/HOLD JUMPER DUST COVER

To test for proper continuity on the jumper wire, connect the ohmmeter to the pins of the dust cover with the jumper wire. There should be continuity — near zero ohms.

MAGNETIC HALL-EFFECT SPEED SENSORS

Caution: Improper connection or voltage could damage the Hall-effect sensor. The Hall-effect sensor works similar to a reed switch, but is solid-state (no moving parts) and requires power in order to function. Also, the speed type of Hall-effect sensor requires alternating magnetic polarities in order to switch. This means that the north pole of a magnet will “open” the Hall effect and the south pole of a magnet will “close” the Hall effect.

Ground pin C (black) and connect clean 12 volts to pin B (white) of the Hall-effect sensor cable. Connect the positive lead (red) of an ohmmeter or continuity tester to pin A (red) and the negative lead (black) of the ohmmeter or continuity tester to pin C of the Hall-effect sensor cable.

Holding the tip of the sensor up to the north pole of a magnet should result in a very high resistance (infinite), while holding the tip of the sensor up to the south pole of a magnet should result in a very low resistance (around 300 ohms).

VANSCO RADAR SPEED SENSOR

Carefully check your installation and operating instructions. The following are tips for troubleshooting;

1. Disconnect the radar adapter cable from the console harness.
2. Check for 12 VDC between pins B and C of the main harness connector (yellow tie). If not present, console or harness may be defective.
3. Using a jumper wire (paper clip bent into a “U”), rapidly short together positions A and C of the main harness speed connector (yellow tie) several times. The console should respond with some speed reading. If not, the console or harness may be defective.
4. Reconnect the radar adapter cable to the main harness speed connection (yellow tie).
5. Disconnect the radar from the radar adapter cable.
6. Check for 12 VDC between pins 1 and 3 of the radar adapter connector. If it is not present but was present in step 2, the radar adapter cable may be defective.
7. Using a jumper wire (paper clip bent into a “U”), rapidly short together positions 2 and 3 of the radar connector (round 4-pin) several times. The console should respond with some speed reading. If not but had a reading in step 3, the radar adapter cable may be defective.
8. If system passes all above tests, the radar may be defective.

Troubleshooting (cont)

Checking Console Inputs with Multimeter

If there is no response from any of the following tests, refer to the main wiring diagram to locate the next connector in line toward the console and repeat the test at that connector. If there is a response at that connector, the problem may be in the cable between the two connectors (or the connectors themselves).

SPEED INPUT

Turn rotary switch to speed position and disconnect the speed sensor (yellow tie) from the main harness. Check harness speed connector for 12V between pins B (wh) and C (blk) and 9V between pins A (red) and C (blk). Using a clip lead or other jumper wire, rapidly short together pins A (red) and C (blk) of the 3-pin connector. **See Illustration below.** If working correctly, the console should show a speed value.

RPM INPUT

Turn rotary switch to RPM and disconnect the RPM sensor (no color tie) from the main harness. Check harness RPM connector for 12V between pins B (wh) and C (blk) and 9V between pins A (red) and C (blk). Using a clip lead or other jumper wire, several times rapidly short together pins A (red) and C (black) of the 3-pin connector. If working correctly, the console should show an RPM rate value.

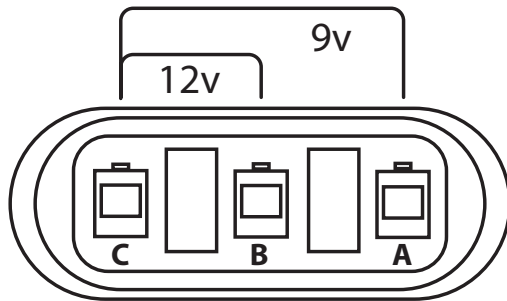

Three-Pin Connector Testing

REMOTE RUN/HOLD INPUT

Disconnect the remote run/hold sensor (or jumper cover) from the main harness. Check harness remote run/hold connector for 12V between pins B (wh) and C (blk) and 9V between pins A (red) and C (blk). Placing a clip lead or other jumper wire between pins A (red) and C (black) of the main harness run/hold connector (gray tie) should turn off the "HOLD" icon on the console display. Removing the jumper should turn on the "HOLD" icon on the console display.

Appendices

Appendix A

Optional Speed Sensor Mounting Installation

Implement Wheels

1. Secure magnets mechanically or with epoxy.
2. Rigidly mount sensor mounting bracket to the wheel assembly. Cut or bend "L" bracket as required for proper positioning of sensor.
3. Install sensor, adjust to correct spacing (1/4" to 1/2" or 6 to 13 mm is recommended), and secure with 3/8" locking nuts. *See Illustration at right.*

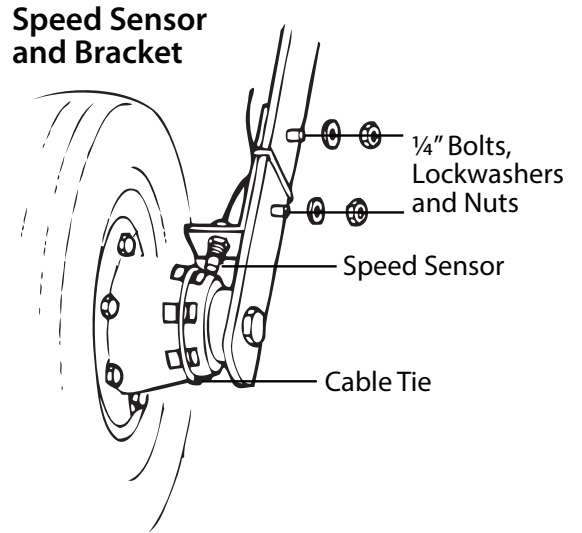

Front Tractor Wheel

1. Magnets may also be secured with a cable tie and an adhesive such as epoxy.
2. Mount the speed sensor bracket to a part of the wheel assembly that does not change position to the hub when the wheels are turned. If the "L" bracket provided cannot be bent and mounted to properly position the sensor, make a bracket similar to the one shown at right.
3. Install sensor, adjust to correct spacing (1/4" to 1/2" or 6 to 13 mm is recommended), and secure with 3/8" locking nuts. *See Illustration below.*

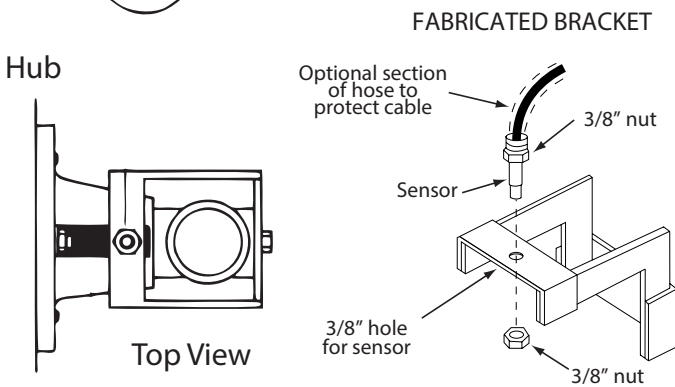
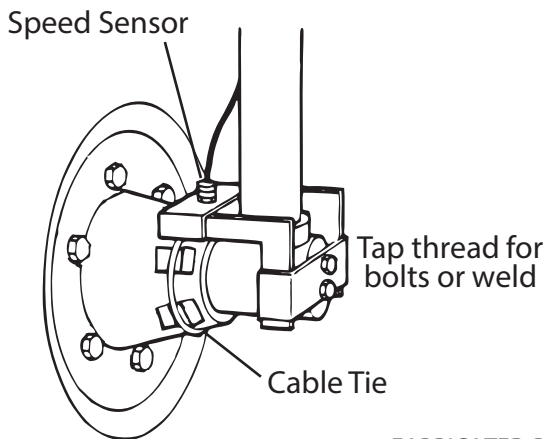

ATV Wheels

Two mounting examples are illustrated.

1. Using one cable tie (ribbed side toward magnets), secure two magnets to the wheel hub so they are exactly opposite each other. Alternate the magnets' polarities.
2. Cut and bend sensor mounting bracket as needed and rigidly mount.
3. Insert sensor, adjust spacing (1/4" to 1/2" or 6 to 13 mm) and secure with 3/8" locking nuts.

CAUTION: Make sure valve stem cannot make contact with sensor or bracket.

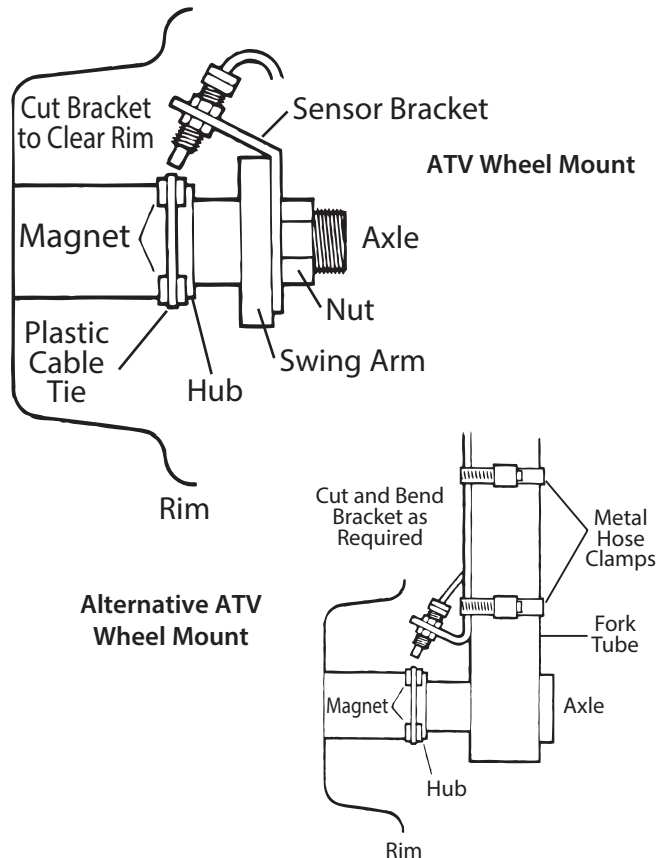

Appendix A (cont)

Optional Speed Sensor Mounting on Drive Shaft

NOTE: This is an optional method generally used on pickups or custom vehicles. It may also be necessary on any other vehicles where access to the wheels is limited. *This installation requires a fine tuning procedure, see page 16.*

Determine the best location for the magnets on drive shaft according to which is the most practical spot to attach sensor mounting bracket. This position should be no more than 12" (.30 meters) behind the front U-joint. For best results, mount "L" bracket to transmission and mount magnets on drive shaft as close to transmission as possible. This will ensure proper alignment if drive train shifts under heavy loading.

Two magnets are required for proper Hall-effect speed sensor operation. Position them exactly opposite each other (180 degrees apart). The polarity (north and south poles) detected by the Hall-effect speed sensor must alternate as the shaft is turned. The magnets provided by Micro-Trak are marked with a dashed line on the SOUTH pole side of the magnet.

- Attach magnets onto drive shaft, one NORTH pole side out and the other SOUTH (dashed) pole side out, by wrapping cable tie around shaft and magnets. Position each magnet so that its longest dimension moves in the direction of rotation. Pull cable tie tight and trim off excess. An adjustable, non-magnetic (stainless steel) band clamp may also be substituted.
- Attach sensor bracket to vehicle transmission. **See *Illustration below.*** Use either the short or long end of the bracket as a base.
- Turn one locking nut onto threaded sensor and insert sensor into large hole selected on mounting bracket. Turn on remaining locking nut. Set sensor to proper distance from magnets (1/4" to 1/2", or 6mm to 13mm). When distance is set, tighten nuts to lock sensor in place.
- Secure sensor cable to frame with cable ties. Place first tie as close to sensor assembly as possible.

See **SPEED CAL** on page 16.

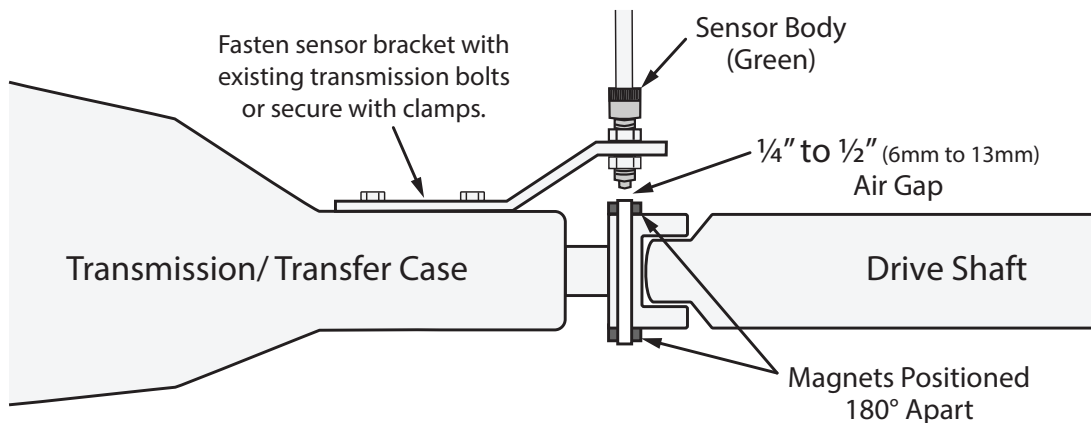

Appendix B

Radar "Y" Adapter Cables

Vansco Radar Amp Connector

P/N 14926



DICKEY-john Radar Amp Connector

P/N 14812

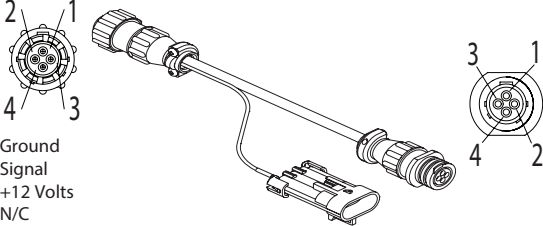

DICKEY-john Radar Cannon Connector

P/N 14813

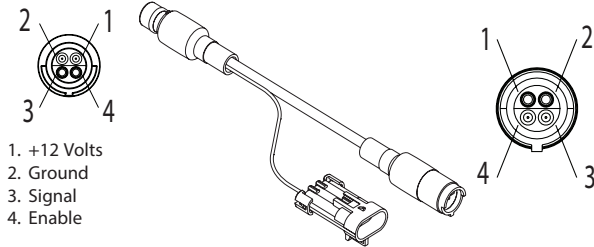

DICKEY-john Radar Deutsch Connector

P/N 14814

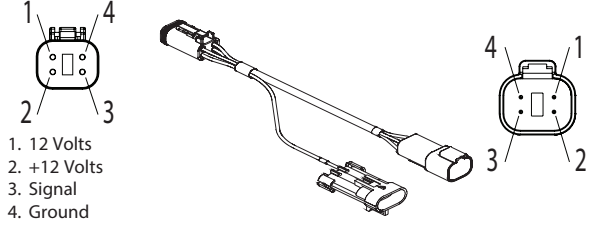

DICKEY-john Radar Ford Connector

P/N 14816

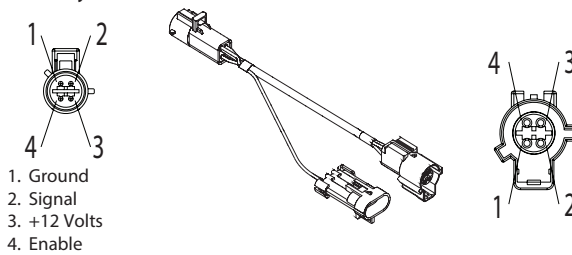

DICKEY-john Radar Packard Connector

P/N 14815

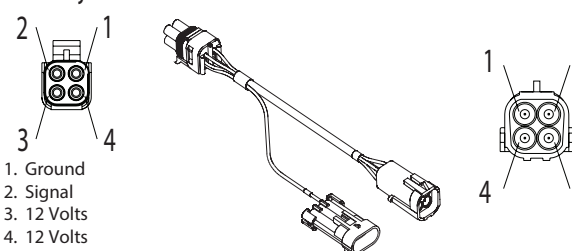

In-Cab Case MX Series Britax Connector

P/N 18319

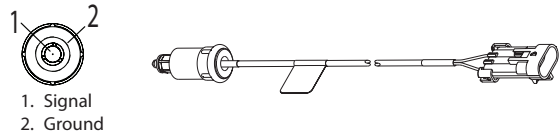

In-Cab John Deere Metri-Pack Connector
8000/9000 Series

P/N 14810

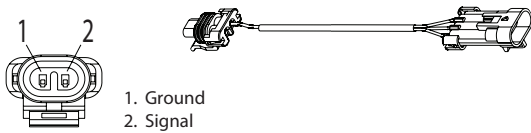

In-Cab John Deere 1-pin M/P 280

P/N 18041

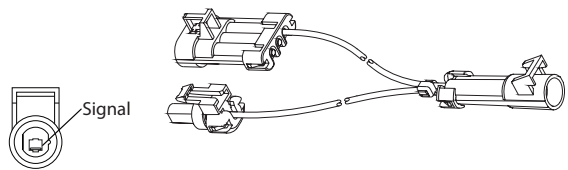

In-Cab John Deere 30 Series 7-pin Amp

P/N 17811

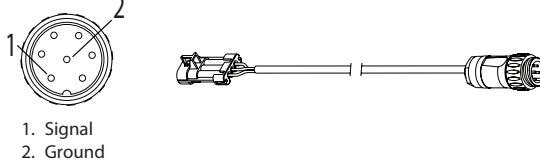

In-Cab John Deere "Y" Connector

P/N 14811

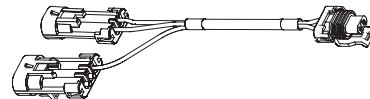

Magnavox & Phillips Radar Packard Connector

P/N 14818

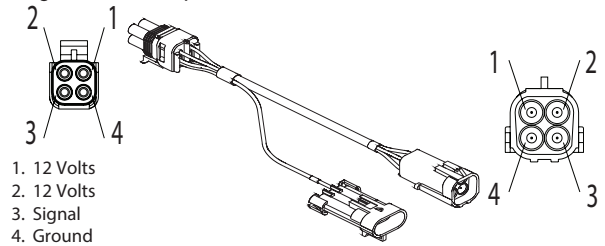

Raven Radar Conxall Connector

P/N 14817

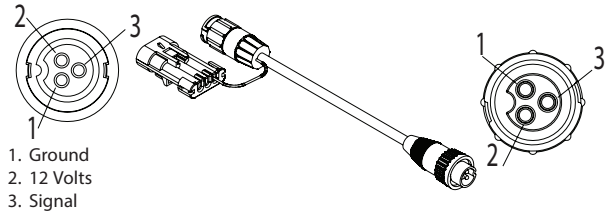

Appendix C

Conversion Chart

English to Metric		
When You Know	Multiple By	To Find
LINEAR MEASUREMENT		
inches	25.4	millimeters
feet	0.305	meters
yards	0.914	meters
miles	1.61	kilometers
LAND MEASUREMENT		
square inches	645.16	square millimeters
square feet	0.093	square meters
square yards	0.836	square meters
acres	.405	hectares
square miles	2.59	square kilometers
LIQUID MEASUREMENT		
fluid ounces	29.57	milliliters
pint	0.473	liters
quart	0.946	liters
gallons	3.785	liters
VOLUME		
cubic feet	0.028	cubic meters
cubic yards	0.765	cubic meters
DRY MEASUREMENT		
quart	1.101	liters
peck	8.810	liters
bushel	35.239	liters
FUEL CONSUMPTION		
10 miles per gallon = 4.25 kilometers per liter		

Metric to English		
When You Know	Multiple By	To Find
LINEAR MEASUREMENT		
millimeters	.039	inches
meters	3.28	feet
meters	1.09	yards
kilometers	.62	miles
LAND MEASUREMENT		
square millimeters	0.00155	square inches
square meters	10.764	square feet
square meters	1.195	square yards
hectares	2.47	acres
square kilometers	0.386	square miles
LIQUID MEASUREMENT		
milliliters	0.034	fluid ounces
liters	0.529	pint
liters	0.264	quart
liters	2.64	gallons
VOLUME		
cubic meters	35.314	cubic feet
cubic meters	1.307	cubic yards
DRY MEASUREMENT		
liters	1.101	quart
liters	8.810	peck
liters	35.239	bushels
FUEL CONSUMPTION		
10 kilometers per liter = 23.5 miles per gallon		

Conversion Abbreviations

Symbols	Symbols	Symbols
in. = inches	pt. = pint	km = kilometers
ft. = feet	qt. = quart	mm ² = square millimeters
yd. = yards	gal. = gallon	m ² = square meters
mi. = miles	ft ³ = cubic feet	ha = hectares
in ² = square inches	yd ³ = cubic yards	km ² square kilometers
ft ² = square feet	pk. = peck	ml = milliliters
yd ² = square yards	bu. = bushel	l = liters
mi ² = square miles	mm = milliliters	dal = dekaliters (10 liters)
fl oz. = fluid ounces	m = meters	m ³ = cubic meters

Appendix D

Replacement Parts List

The following replacement parts are available from your dealer or distributor.

Micro-Trak Systems, Inc.
1305 Stadium Rd.
Mankato, MN 56001-5355

When ordering parts, please list the model number of your console, and the description and part number of each part that you want to order.

<u>Part Number</u>	<u>Description</u>
12069	Magnet kit (6 magnets per kit)
10013	Speed sensor mount bracket
12910	14" Black plastic cable ties (bag of 10)
13181	Console mount kit*
12888	Console mount knob
12889	Console mount washer
13226	5-foot remote run/hold or RPM sensor cable
13096	5-foot Speed sensor cable
01530	Speed sensor kit
01535	Remote run/hold sensor kit
01539	Shaft RPM sensor kit
17176	Power/Speed/Run-Hold/RPM Harness

*The Console Mount Kit is available only as a kit, some parts not available for sale as individual components. Parts and design specifications subject to change without notice.

Optional 3-Pin and 10-Pin Metri-Pack 150 extension cables:

Part No.	M/P 3-Pin	Part No.	M/P 10-Pin
13205	5-foot	13220	5-foot
13206	10-foot	13221	10-foot
13207	15-foot	13222	15-foot
13208	20-foot	13223	20-foot
13209	25-foot	13224	25-foot
13419	50-foot	17095	30-foot
		17096	40-foot
		17269	45-foot
		14142	50-foot



1305 Stadium Road, Mankato, MN 56001-5355

Toll-Free: 800-328-9613

507-257-3600

www.micro-trak.com • trakmail@micro-trak.com

Copyright © 2021 Micro-Trak Systems, Inc.

All Rights Reserved.